



---

Product Brochure

# PXI Vector Signal Transceivers

# Contents

[PXI Vector Signal Transceivers](#)

[PXIe-5842: NI's Third Generation VST](#)

[Detailed View of PXIe-5842](#)

[Detailed View of PXIe-5842 with 54 GHz Frequency Extension](#)

[Key Features](#)

[Software Overview](#)

[What is PXI?](#)

[PXI Instrumentation](#)

[Supporting Documentation](#)

[Configure a Custom NI System](#)

[NI Hardware Services](#)

# PXI Vector Signal Transceivers

PXIe-5842, PXIe-5831, PXIe-5830, PXIe-5841, PXIe-5820, PXIe-5655, PXIe-5646, PXIe-5645, and PXIe-5644



- Generate and acquire wide instantaneous bandwidth from baseband through RF in one instrument for test and measurement
- Ensure test coverage for new and legacy wireless standards, including 5G NR and all Wi-Fi bands
- Stream high-speed data to and from the instrument through the front panel digital I/O
- Achieve best-in-class EVM performance for higher-order modulation schemes, such as Wi-Fi 7, Bluetooth, and 5G NR
- Synchronize multiple VSTs with phase-coherent generation and acquisition for true MIMO applications
- Utilize I/Q baseband signals for wideband testing and envelope tracking applications
- Take advantage of easy-to-use software with soft front panels for interactive control and extensive measurement API for rapid test automation

## Built for RF Automated Test and Measurement

The PXI Vector Signal Transceiver (VST) combines a vector signal analyzer and vector signal generator with a powerful FPGA and high-speed serial and parallel digital interfaces for real-time signal processing and control. With up to 2 GHz of instantaneous RF or complex I/Q bandwidth, the NI VST is ideally suited for a wide range of applications, including RFIC validation and production testing, radar prototyping, and other RF wideband test scenarios.

The VST product line provides the high performance necessary to support lab design and validation applications while incorporating the fast measurement speed and small form factor required to scale production test applications. You can use VST instruments throughout the design cycle from design to validation to production test—minimizing measurement correlation errors and improving efficiency with test software reuse. The VST can be used to test a variety of cellular and wireless standards, including 5G NR, Wi-Fi 7, Ultra-Wideband (UWB), and Bluetooth. The modular PXI platform allows users to configure systems with multiple VSTs to support multiple input, multiple output (MIMO) applications and simplify synchronization between instruments thanks to shared timing and synchronization resources in the PXI chassis.

The software that supports the VST provides several layers of functionality:

- RFmx soft front panels integrated into InstrumentStudio™ software for fast, interactive instrument configuration and measurement execution
- Measurement-focused APIs that abstract complex RF measurement science into a few function calls
- A suite of ready-to-run automation examples that provide a foundation for building cohesive automated test and measurement applications

Table 1. NI's VST Portfolio

|   | 3rd Generation VST | 2nd Generation VST            |   |
|---|--------------------|-------------------------------|---|
|   | PXIe-5842          | PXIe-5830/1                   | PXIe-5841                                 |
| Frequency Range                         | 30 MHz to 26.5 GHz | 5 GHz to 21 GHz               | 9 KHz to 6 GHz                            |
| Instantaneous Bandwidth                 | Up to 2 GHz        | 1 GHz                         | 1 GHz                                     |
| Channels                                | RF In<br>RF Out    | Up to 32 In/Out<br>(switched) | 1 In<br>1 Out                             |
| EVM (Wi-Fi 6 80 MHz, loopback @ 6 GHz)  | -56 dB             | -50 dB                        | -48 dB                                    |
| EVM (5G NR 100 MHz, loopback @ 5.5 GHz) | -58 dB             | -51 dB                        | -49 dB                                    |
| EVM (5G NR 100 MHz, loopback @ 28 GHz)  | -44 dB             | -44 dB                        | N/A                                       |
| VSG Maximum Output Power (CW @ 5 GHz)   | +25 dBm            | +12 dBm                       | +20 dBm                                   |
| Tuning Time                             | 230 $\mu$ s        | See Specifications            | 380 $\mu$ s<br>175 $\mu$ s with PXIe-5655 |
| Slots                                   | 4 to 6             | 4 to 6                        | 2 to 3                                    |
| Frequency Extension                     | Yes, up to 54 GHz  | Yes, up to 44 GHz             | No  |

Notes: This table provides an overview of NI's VST Line; refer to the Product Specifications for more information. PXIe-5842 EVM includes noise compensation. All specifications are typical.

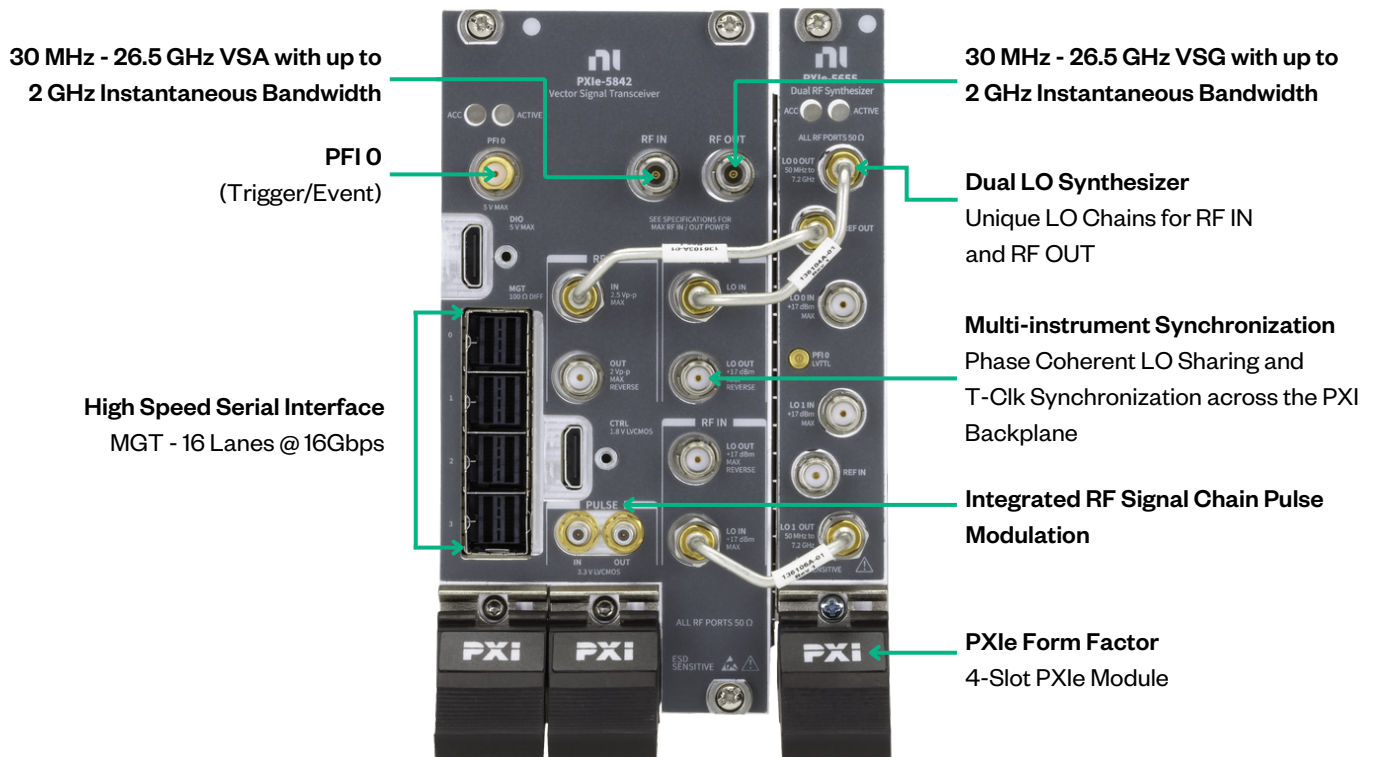
## PXIe-5842: NI's Third Generation VST

The latest addition to NI's family of VSTs, the PXIe-5842 brings much improved measurement capabilities and new features applicable to a wide range of RF applications. Among the new capabilities are best-in-class EVM performance (802.11be, 320 MHz BW, < -50 dB), enhanced LO Offset mode with improved average noise density, continuous frequency coverage up to 26.5 GHz, and up to 2 GHz of instantaneous RF bandwidth.

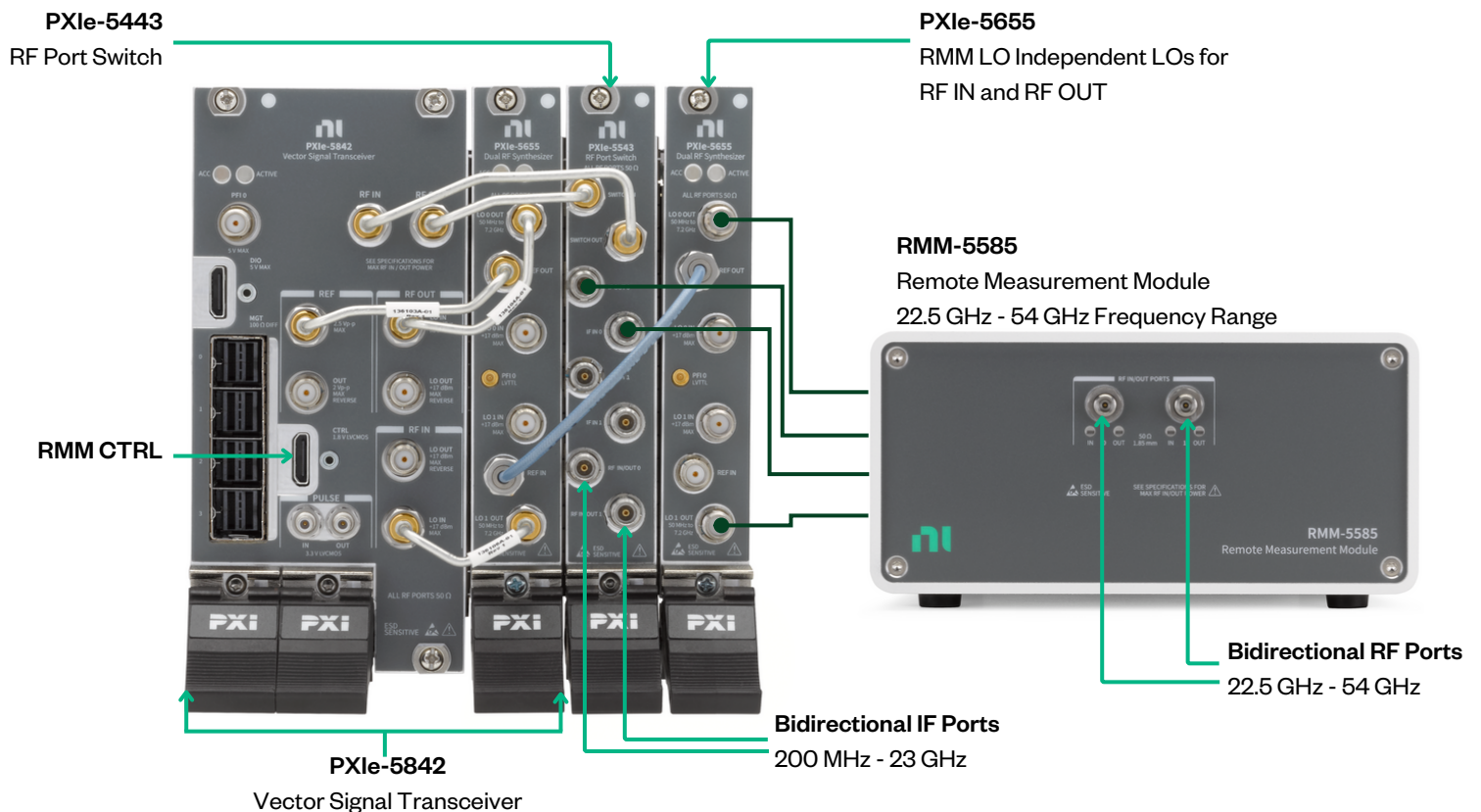


FIGURE 1  
The Third Generation VST, PXIe-5842

## Detailed View of the PXIe-5842 VST



## Detailed View of the PXIe-5842 with 54 GHz Frequency Extension



# Key Features

## Instantaneous Bandwidth for Wideband Applications

From next-generation wireless technologies like Wi-Fi 7 (802.11be), Ultra-Wideband, and 5G NR to advanced aerospace and defense applications like radar tests and spectrum monitoring, there is a demand for wider signal bandwidth to achieve higher peak data rates. Leveraging fast sampling, high-linearity DACs and ADCs, and wideband internal calibration mechanisms, NI VSTs offer 200 MHz, 500 MHz, 1 GHz, or 2 GHz of instantaneous RF and complex I/Q bandwidth with excellent measurement accuracy.

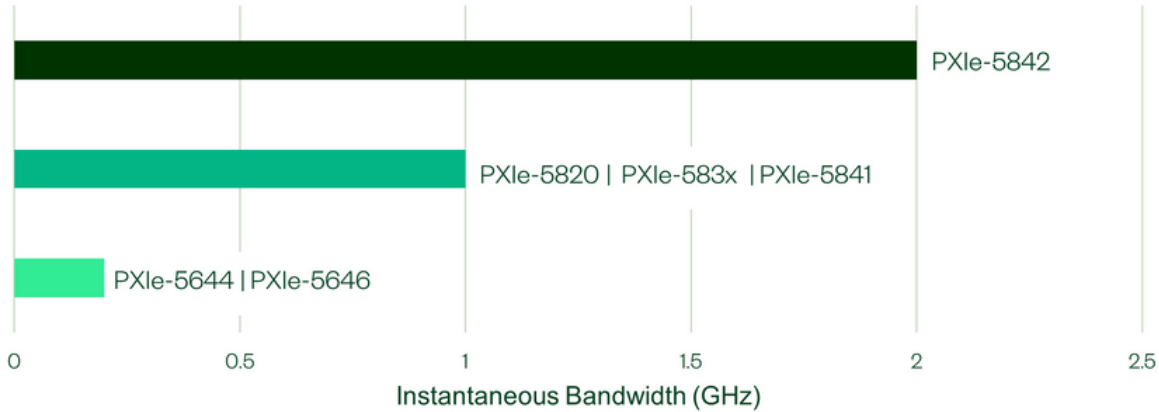


FIGURE 2  
Instantaneous RF Bandwidth in GHz of NI VST Models

Wider bandwidth introduces the need for advanced signal processing at higher throughputs. The VST addresses this requirement by offering FPGA-based signal processing for applications such as radar target simulation, multi-carrier aggregation, digital pre-distortion algorithm implementations, and real-time spectrum analysis. Additionally, the VST incorporates patented algorithms for amplitude and phase correction for high absolute amplitude accuracy and low deviation from linear phase across the span of their wide instantaneous bandwidth.

Linearization of wideband RF power amplifiers with digital pre-distortion (DPD) is a popular technique to improve modulation quality and spectral emissions. With bandwidth requirements often three to five times higher than the signal bandwidth for DPD, this can mean anywhere from 1,600 to 2,000 MHz bandwidth is required for the latest Wi-Fi 7 and 5G NR waveforms. Using the wideband capabilities available with NI VSTs (up to 2 GHz), this is possible with modulation schemes such as Wi-Fi 7 and 5G NR that include bandwidths of up to 320 MHz and 400 MHz, respectively.

## Wide Frequency Range

VSTs offer a broad frequency coverage from baseband to 54 GHz. NI provides a full suite of software for spectral and wireless standards measurements to test a wide range of wireless technologies like Wi-Fi 7 and 5G NR even as they expand to different frequency bands.

The PXIe-5842 offers continuous frequency coverage from 30 MHz to 26.5 GHz in one instrument. This further reduces the complexity of instrumentation required for a versatile RF system. Applications and standards ranging from Wi-Fi, Ultra-Wideband, Bluetooth, 5G NR, and radio prototyping can now coexist and be consolidated onto one capable and versatile instrument.

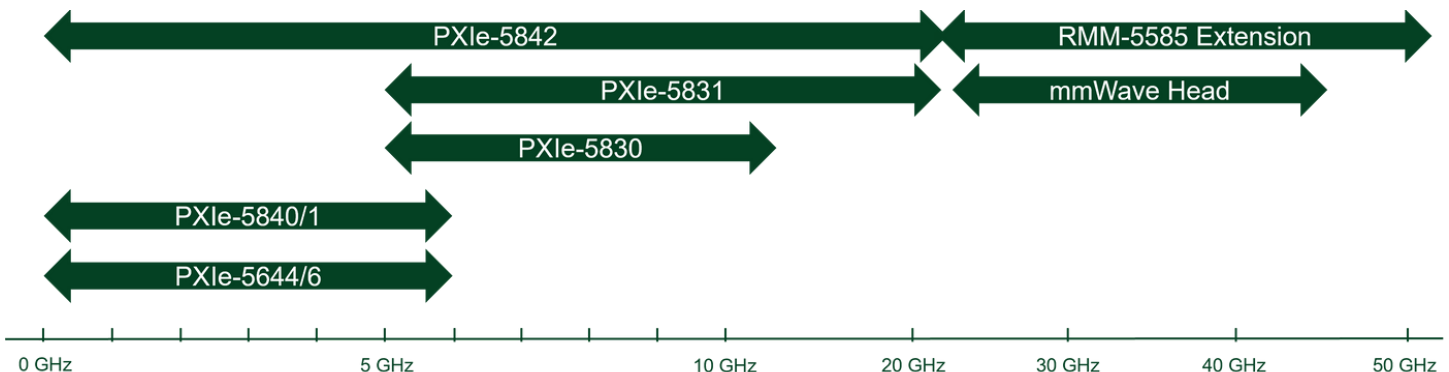


FIGURE 3  
Spectrum Coverage of the VST Portfolio

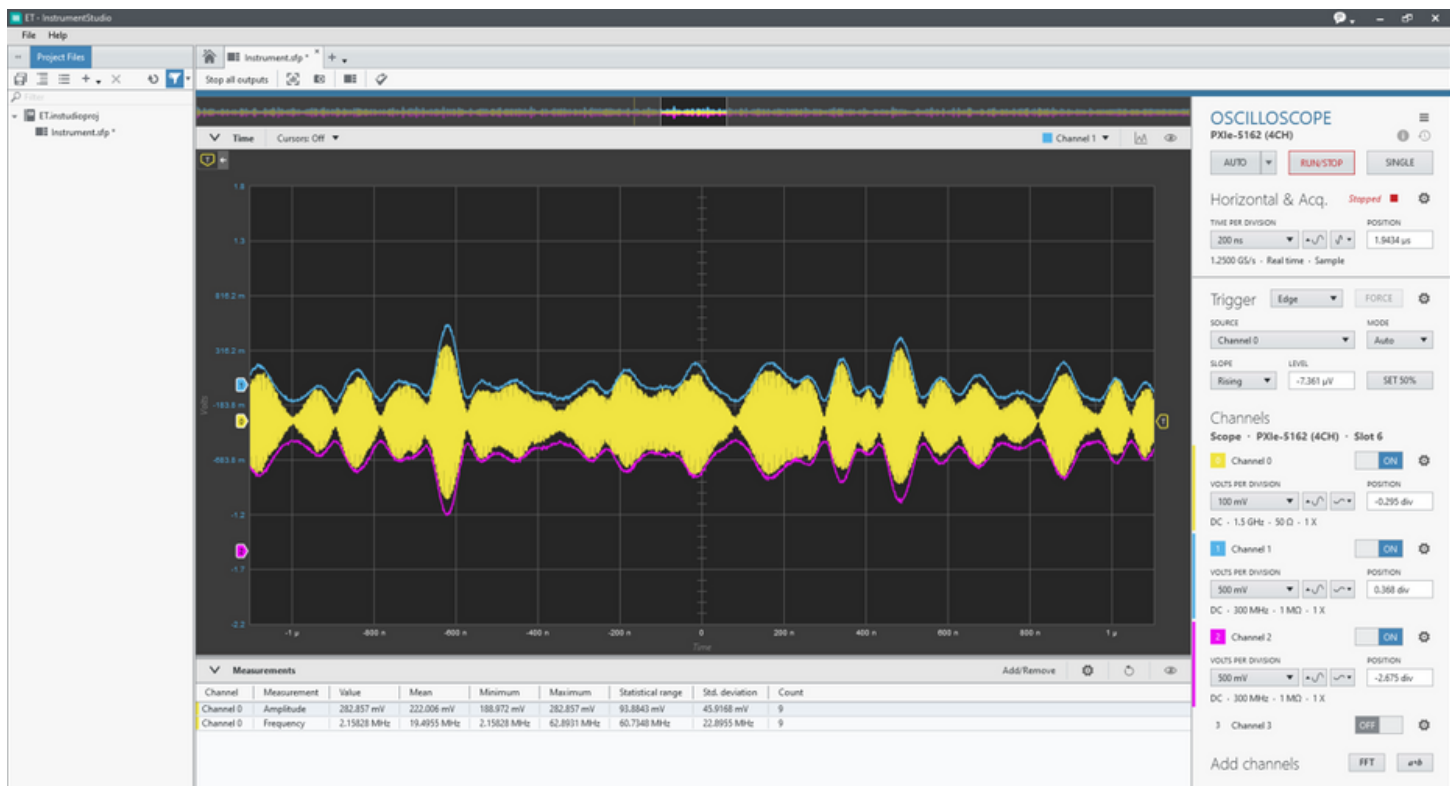
Including the RMM-5585 Remote Measurement Module, the PXIe-5842 VST can extend up to 54 GHz center frequency with 2 GHz of instantaneous RF bandwidth. With two bidirectional channels, setting up and configuring conducted and OTA test requirements for mmWave applications in a single, tightly synchronized instrument with minimal path loss is easy. The RF IN and RF OUT ports can be used simultaneously with independent frequency tuning, allowing many different test configurations and use cases.

The PXIe-5842 VST also includes two IF test ports that can be used independently or in conjunction with the remote measurement module. These ports provide frequency coverage from 200 MHz to 23 GHz and offer a direct interface for multifrequency devices like frequency upconverters/downconverters or beamformer ICs with built-in frequency conversion.

## Baseband I/Q Functionality

For engineers that require high bandwidth analog baseband signals, the PXIe-5820 VST combines a wideband I/Q digitizer and arbitrary waveform generator into a single two-slot PXI Express module. The PXIe-5820 offers up to 1 GHz real-time baseband complex I/Q generation and analysis and supports programmable common mode ranging and voltage swing. The combination of high-linearity, low-phase noise, and patented IQ calibration techniques enables the PXIe-5820 to achieve better than -54 dB EVM performance with higher order modulation schemes, such as Wi-Fi 6 1024 QAM.

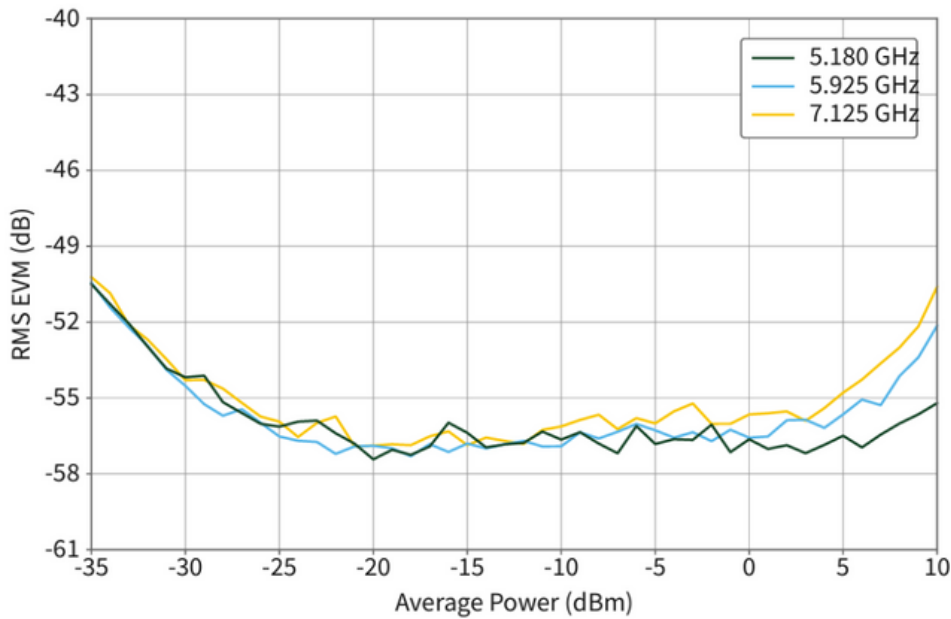
Additionally, engineers can synchronize the PXIe-5820 baseband VST with other RF VSTs and additional DC, analog, and digital PXIe instruments to create a unified test bench for complex envelope tracking applications.



**FIGURE 4**  
Using RFmx to Perform Envelope Tracking and Multi-Instrument Synchronization

## Wideband EVM Measurement Performance

The VST uses advanced, patented IQ calibration techniques and high-quality RF instrumentation to deliver best-in-class EVM performance for wideband signals. With higher-order modulation schemes and wideband multi-carrier signal configurations, the RF front ends of today's wireless devices require better linearity and lower phase noise. NI's RF test instrumentation provides even more accurate and reliable performance to measure complex and demanding modulation schemes.



**Conditions:**

PAPR: 9.95 dB; MCS index: 11; 16 OFDM data symbols; 20 packet averages; channel estimation type: Ch Estimation Ref (Preamble and Pilots); Reference Level = Average Power Level + Waveform PAPR; RF OUT Digital Gain Servo technique (increase RF OUT Digital Gain until DSP overflow reported) applied; ModAcc Auto Level: Enabled; Reference Level headroom: 1 dB (default)

**FIGURE 5**

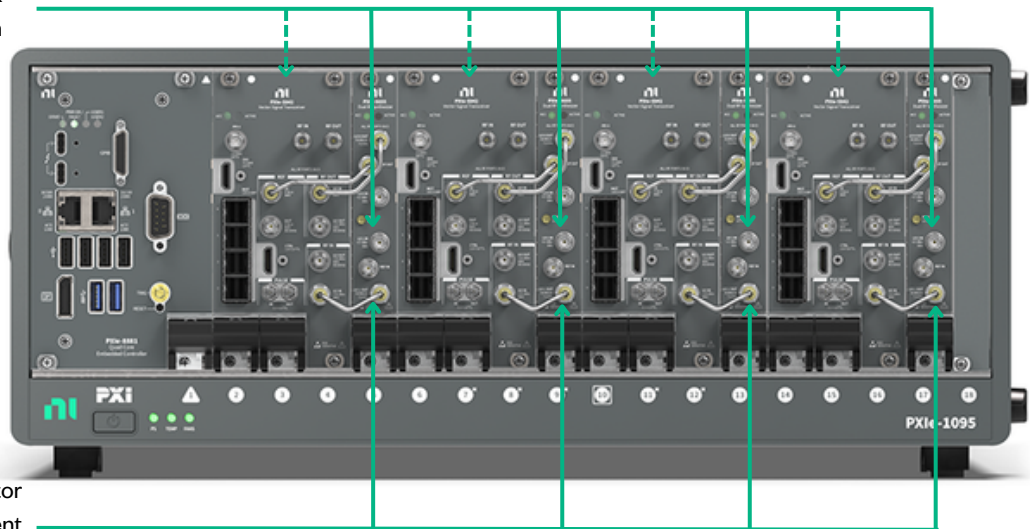
WLAN 802.11ax 80 MHz RMS EVM, 1024-QAM (PXIe-5842, loopback) versus Average Power, Measured

Engineers can push the EVM performance of the VST even lower by pairing it with a PXI Local Oscillator. Systems based on the second generation VST (PXIe-5820, PXIe-5841, PXIe-583x) can achieve EVM performance better than -50 dB for high order modulation applications, such as Wi-Fi 6/7 and 5G NR. As shown in Figure 6, the PXIe-5842 delivers industry-leading EVM performance, with better than -56 dB in a similar setup.

## Modular and Easily Synchronized

Engineers are employing multiple input, multiple output (MIMO) systems in a wide range of electronic warfare and radar applications ranging from phased array radars to beamforming and direction-finding systems. Modern communications standards like Wi-Fi 7 and 5G NR also use MIMO schemes with multiple RF chains on a single device to provide a combination of higher data rates through more spatial streams and more robust communications through beamforming. NI enables engineers to achieve phase coherent generation and analysis for two, four, eight, or more VSTs to support other advanced test configurations.

Simplified Reference Clock and Trigger Distribution



Shared Common Oscillator for Phase Alignment

**FIGURE 6**

Typical 4x4 MIMO System with Four PXIe-5842 VSTs

As shown in Figure 6, the PXIe-5842 can support up to a 4x4 MIMO configuration. For an even larger systems, fit up to eight PXIe-5841 VSTs for an 8x8 phase coherent MIMO system or connect multiple PXIe chassis in a unified multi-chassis configuration.



## Improved Tuning Time

With a typical LO tuning time below 175  $\mu$ S, the PXle-5841 with PXle-5655 Local Oscillator and the PXle-5842 can support applications that require very low latency frequency hopping common to aerospace and defense applications. These applications include radar target simulation, spectrum monitoring in electronic warfare, and key parametric measurements for TR module test of AESA radar. Additionally, this enhancement will reduce test time by reducing individual measurement times.

The PXle-5655 is an optional add-on to the PXle-5841 to achieve an improved tuning time. The PXle-5655 is an integral component and is included with the PXle-5842.

## Flexible Digital Interface

The VST features a flexible digital interface capable of both high-speed parallel and serial communication. In the PXle-5841, the digital lines are directly connected to a user-programmable FPGA through level shifting buffers. The digital lines exposed on the front panel support various standard voltage levels.

The high-speed serial interface on the PXle-5841 features four multi-gigabit transceivers (MGTs) that operate at data rates of up to 12 Gb/s per lane and support high-speed serial standards, such as Xilinx Aurora and Serial RapidIO. Users can stream full bandwidth I/Q data out of the front panel to external signal processing modules. Thus, engineers have two data streaming options: the front panel connector or the PCI Express backplane.

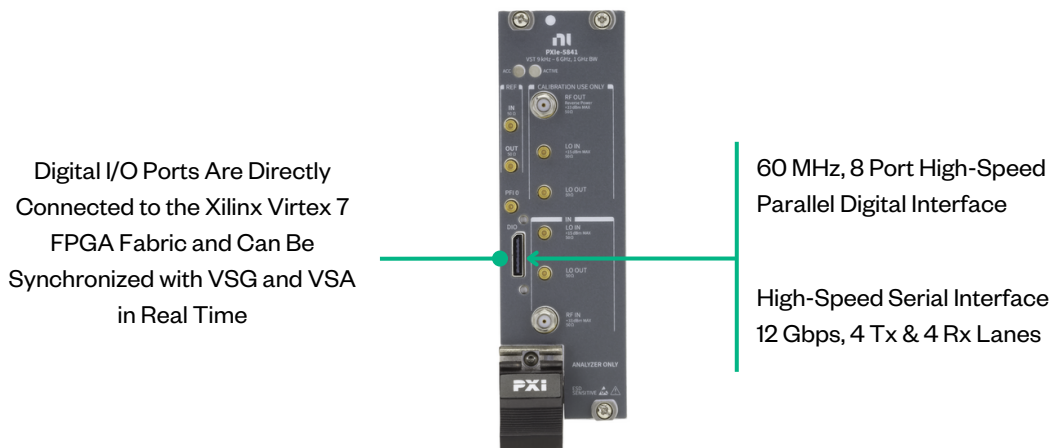


FIGURE 7

Digital Interfacing Ports on the PXle-5841 Front Panel

The PXle-5842 improves further on this capability, with four MGT connectors capable of up to 16 Gb/s per lane. This enables streaming at full data rates for high-bandwidth applications while maintaining the tight synchronization with highly integrated signal processing modules. Contact NI for more information on data streaming with the PXle-5842.

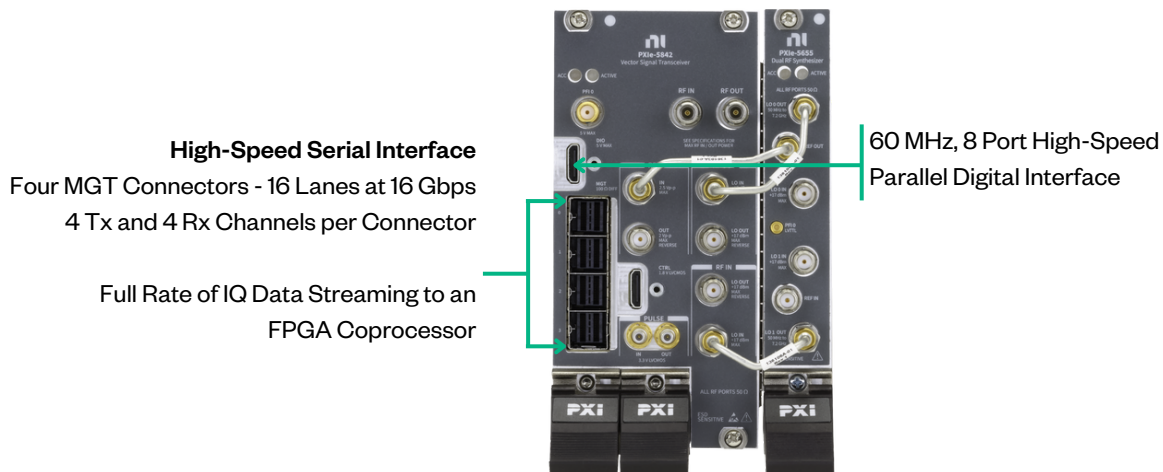


FIGURE 8

Digital Interfacing Ports on the PXle-5842 Front Panel

# RF Pulse Capabilities

Engineers are utilizing advanced RF pulse capabilities to generate tailored pulsed signals to revolutionize the design, testing, and optimization of modern communication and radar systems. Adjustable parameters such as pulse width, rise time, and repetition rates empower engineers to recreate real-world scenarios, such as simulating diverse modulation schemes and bandwidth optimization in communication systems, as well as testing and validating radar hardware and algorithms.

New to the PXIe-5842 VST are dedicated pulse input and output connections found on the instrument's front panel. The integrated RF signal chain allows for a wide range of pulse widths, pulse repetition interval (PRI), and optimizing on/off ratios versus pulse width for native pulsed generation capabilities in communications, control systems, and radar and electronic warfare applications.

Engineers can control the pulse modulation using either sample-based markers in a generated waveform or externally with the dedicated Pulse In input connector optimized for low latency and jitter. A digital trigger can also be aligned to the RF pulse edge and exported from the dedicated Pulse Out connector. When combined with RFmx Pulse, the VST can generate and measure different pulse types, modulation schemes, and various measurements to make taking pulse measurements intuitive alongside existing RFmx personalities for a complete set of RF measurement capabilities.

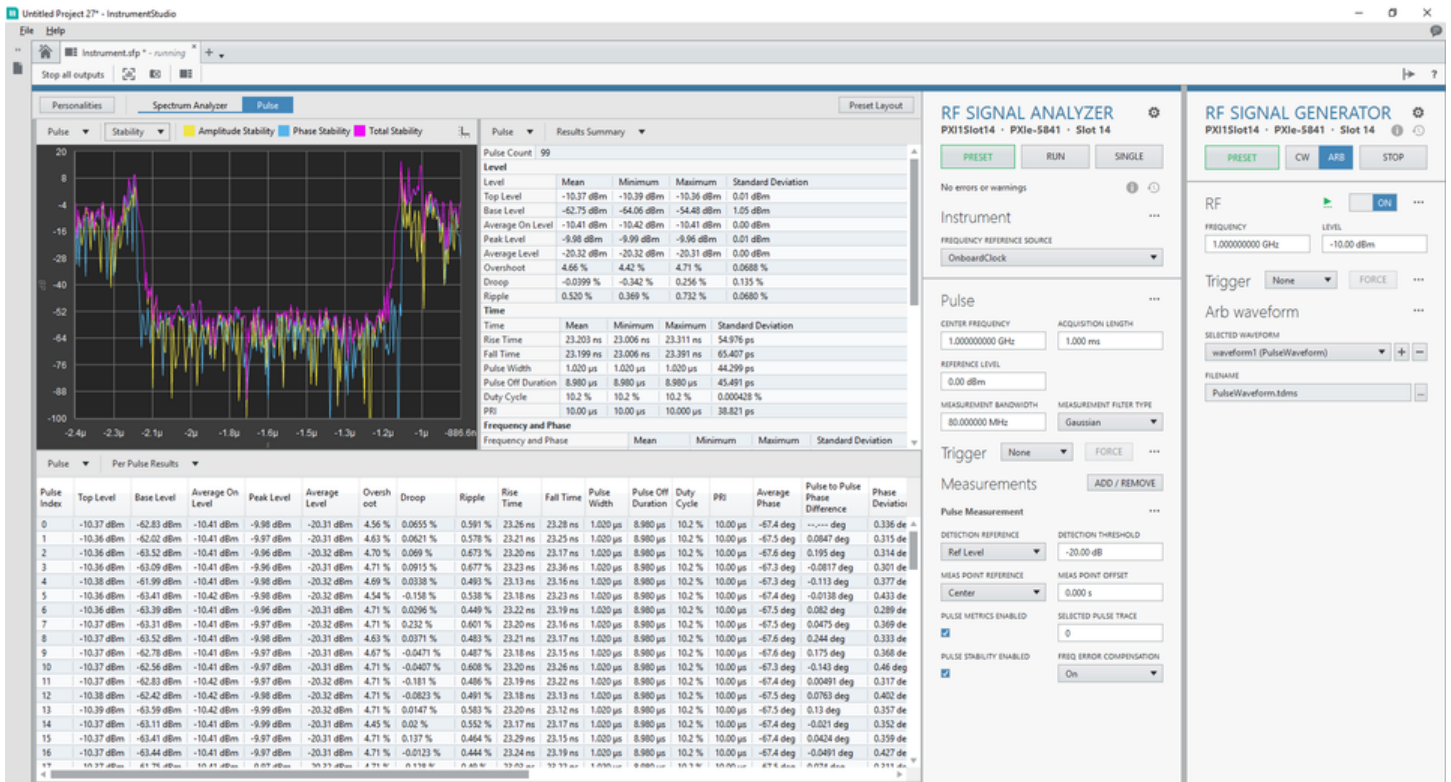


FIGURE 9 RFmx Pulse Generating and Analyzing the Stability of a Pulsed Waveform

# Software Overview

## RFmx

RFmx is a set of interoperable measurement personalities together with waveform creation software that extends the capability of NI RF instrumentation for general-purpose, connectivity, cellular, and aerospace and defense test applications. Using RFmx, you can perform and debug measurements quickly and easily with interactive software front panels, create and play back open, unlocked waveforms with RFmx Waveform Creator, and speed up automated testing with the performance-optimized API.

RFmx is integrated natively in InstrumentStudio, meaning all RFmx soft front panels can coexist alongside other instrument types, and custom measurement configurations can be saved and reopened for quick and easy transition between test cases. These configurations can also be exported to code for a fast transition to automated test and characterization.

Using RFmx with NI VST, you can achieve excellent RF performance with ultrafast measurement speeds, enabling you to create test systems that span your entire product lifecycle from design validation to production test.

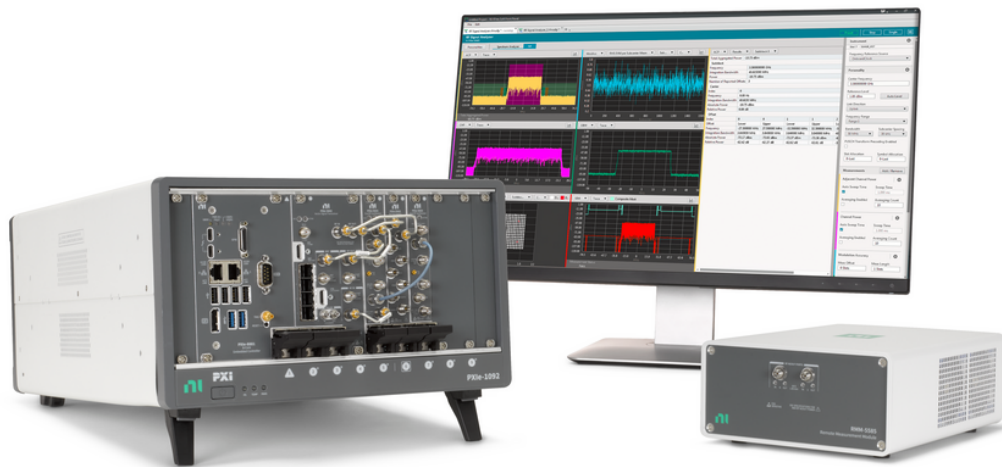


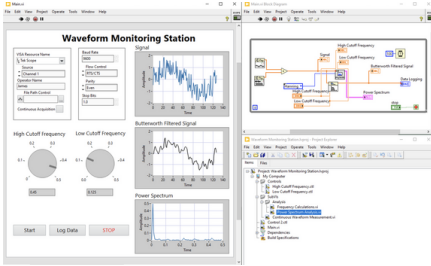
FIGURE 10

Use RFmx Soft Front Panels for Interactive Measurement and Debugging of Complex RF Signals

# NI Software- The Right Tool for the Job

NI has a variety of software for engineers working on research, validation, and production test applications. Learn about our software that helps engineers perform quick ad-hoc tests, build an automated test system, automate data analysis and reporting, develop test sequences, and more.

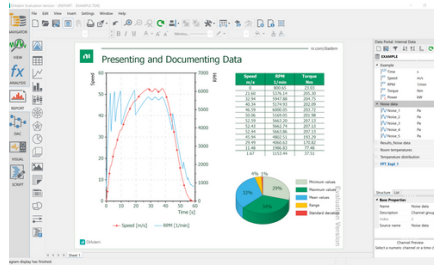
## LabVIEW



Graphical programming environment that engineers use to develop automated research, validation, and production test systems.

- Acquire data from NI and third-party hardware and communicate using industry protocols
- Use configurable, interactive display elements
- Take advantage of available analysis functions

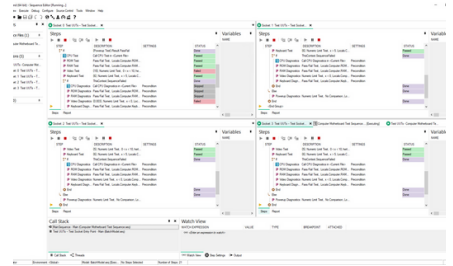
## DIAdem



Data analytics software for measurement data search, inspection, analysis, and automated reporting.

- Display data in multiple 2D-axis systems
- Perform calculations with a simple point-and-click interface
- Automate your measurement data analysis workflow, from import to analysis

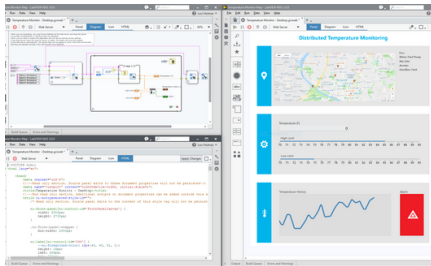
## TestStand



Test executive software that accelerates system development for engineers in validation and production.

- Call and execute tests in LabVIEW, Python, C/C++, or .NET
- Conduct complex tasks, such as parallel testing
- Create customer operator interfaces and robust tools for deployment and debugging

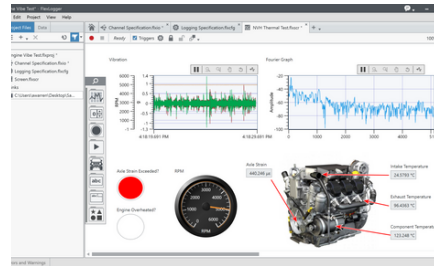
## G Web



Development software that helps engineers create web-based user interfaces without the need for traditional web development skills.

- Data transfer APIs for connecting to systems written in LabVIEW, Python, or C#
- Pre-built objects for data display and user input
- Included hosting on SystemLink™ Cloud

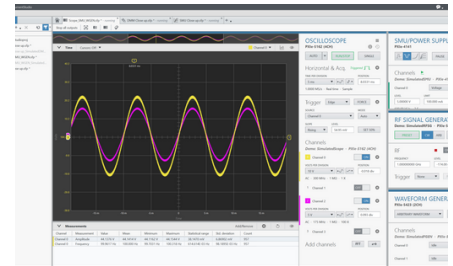
## FlexLogger™



No-code data acquisition software engineers use to build validation and verification test applications.

- Interactive visualization tools for monitoring tests with drag-and-drop charts, graphs, and controls
- Ability to set alarms that monitor single channels or groups for unexpected behavior

## InstrumentStudio™

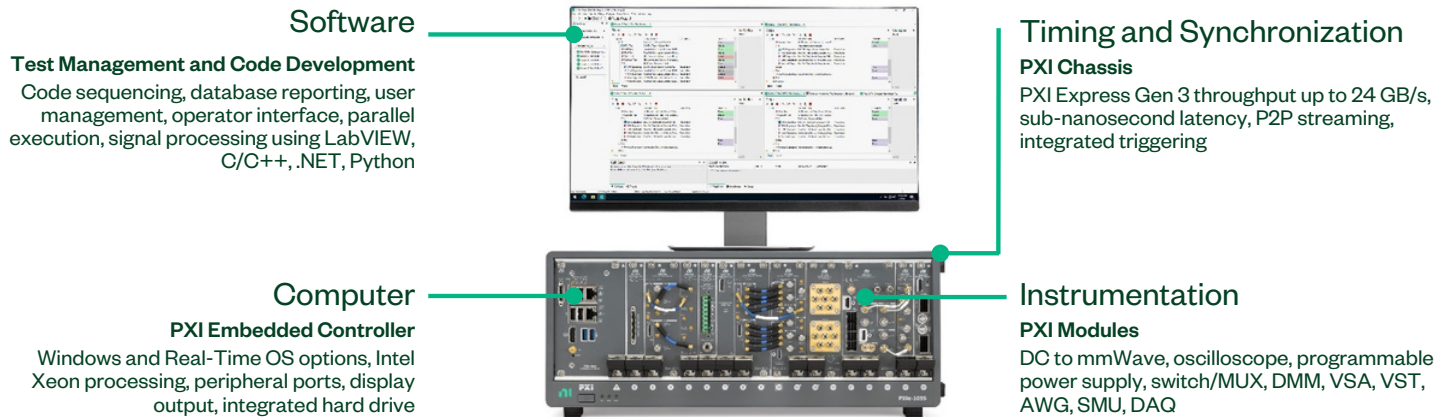


Application software that simplifies setup and configuration of NI PXI hardware

- Customizable layouts for monitoring multiple instruments at once
- Interactively debug in tandem with code
- TDMS file export containing instrument settings, measurements, and raw data





# What is PXI?

Powered by software, PXI is a rugged PC-based platform for measurement and automation systems. PXI combines PCI electrical-bus features with the modular, Eurocard packaging of CompactPCI and then adds specialized synchronization buses and key software features. PXI is both a high-performance and low-cost deployment platform for applications such as manufacturing test, military and aerospace, machine monitoring, automotive, and industrial test. Developed in 1997 and launched in 1998, PXI is an open industry standard governed by the PXI Systems Alliance (PXISA), a group of more than 70 companies chartered to promote the PXI standard, ensure interoperability, and maintain the PXI specification.



## Integrating the Latest Commercial Technology

By leveraging the latest commercial technology, we can continually deliver high-performance and high-quality products to our users at a competitive price. The latest PCI Express Gen 3 switches deliver higher data throughput, the latest Intel multicore processors facilitate faster and more efficient parallel (multisite) testing, the latest FPGAs from Xilinx help to push signal processing algorithms to the edge to accelerate measurements, and the latest data converters from TI and ADI continually increase the measurement range and performance of our instrumentation.

|  |  |   |   |
|--|--|---|---|
| <p><b>HIGHER DATA THROUGHPUT</b></p>  <p><b>PCI Express Gen 3</b></p> | <p><b>PARALLEL TEST EXECUTION</b></p>  <p><b>Multicore Processors</b></p> | <p><b>MEASUREMENT ACCELERATION</b></p>  <p><b>FPGAs</b></p> | <p><b>INCREASED MEASUREMENT RANGE</b></p>  <p><b>Data Converters</b></p> |
|--|--|---|---|

# PXI Instrumentation

NI offers more than 600 different PXI modules ranging from DC to mmWave. Because PXI is an open industry standard, nearly 1,500 products are available from more than 70 different instrument vendors. With standard processing and control functions designated to a controller, PXI instruments need to contain only the actual instrumentation circuitry, which provides effective performance in a small footprint. Combined with a chassis and controller, PXI systems feature high-throughput data movement using PCI Express bus interfaces and sub-nanosecond synchronization with integrated timing and triggering.



## Oscilloscopes

Sample at speeds up to 12.5 GS/s with 5 GHz of analog bandwidth, featuring numerous triggering modes and deep onboard memory



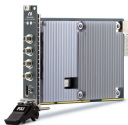
## Digital Multimeters

Perform voltage (up to 1000 V), current (up to 3A), resistance, inductance, capacitance, and frequency/period measurements, as well as diode tests



## Digital Instruments

Perform characterization and production test of semiconductor devices with timing sets and per channel pin parametric measurement unit (PPMU)



## Waveform Generators

Generate standard functions including sine, square, triangle, and ramp as well as user-defined, arbitrary waveforms



## Frequency Counters

Perform counter timer tasks such as event counting and encoder position, period, pulse, and frequency measurements



## Source Measure Units

Combine high-precision source and measure capability with high channel density, deterministic hardware sequencing, and SourceAdapt transient optimization



## Power Supplies & Loads

Supply programmable DC power, with some modules including isolated channels, output disconnect functionality, and remote sense



## FlexRIO Custom Instruments & Processing

Provide high-performance I/O and powerful FPGAs for applications that require more than standard instruments can offer



## Switches (Matrix & MUX)

Feature a variety of relay types and row/column configurations to simplify wiring in automated test systems



## Vector Signal Transceivers

Combine a vector signal generator and vector signal analyzer with FPGA-based, real-time signal processing and control



## GPIB, Serial, & Ethernet

Integrate non-PXI instruments into a PXI system through various instrument control interfaces



## Data Acquisition Modules

Provide a mix of analog I/O, digital I/O, counter/timer, and trigger functionality for measuring electrical or physical phenomena

# Supporting Documentation

Table 2. VST Supporting Documentation

| Document Type         | Model #Number   |
|-----------------------|---|
| Getting Started Guide | <a href="#">PXIe-5842</a> , <a href="#">PXIe-5841</a> , <a href="#">PXIe-5832</a> , <a href="#">PXIe-5831</a> , <a href="#">PXIe-5830</a> , <a href="#">PXIe-5820</a> |
| Specifications        | <a href="#">PXIe-5842</a> , <a href="#">PXIe-5841</a> , <a href="#">PXIe-5832</a> , <a href="#">PXIe-5831</a> , <a href="#">PXIe-5830</a> , <a href="#">PXIe-5820</a> |
| Features              | <a href="#">PXIe-5842</a> , <a href="#">PXIe-5841</a> , <a href="#">PXIe-5832</a> , <a href="#">PXIe-5831</a> , <a href="#">PXIe-5830</a> , <a href="#">PXIe-5820</a> |

## Configure a Custom NI System

NI's online system advisors help you create a custom system based on your requirements. Use the advisor to choose compatible hardware, software, accessories, and services, and then save your selections as configurations for easy quoting and purchasing later. Visit [ni.com/Advisor](http://ni.com/Advisor) to learn more.

# NI Hardware Services

All NI hardware includes a one-year warranty for basic repair coverage and calibration in adherence to NI specifications prior to shipment. PXI systems also include basic assembly and a functional test. NI offers additional entitlements to improve uptime and lower maintenance costs with service programs for hardware. Learn more at [ni.com/services/hardware](https://ni.com/services/hardware).

|  | Hardware                    | Standard          | Premium           | Description   |
|--|-----------------------------|-------------------|-------------------|---|
| Duration at Point of Sale                      | 1 year; included            | 3 years; optional | 3 years; optional | NI enhances warranty coverage with additional service benefits provided with a hardware service program.  |
| Maximum Duration with Renewal                  | ≤3 Years w/ Service Program | ≤3 Years          | ≤3 Years          | NI maintains the high performance and availability of your hardware for up to three years with a hardware service program.                              |
| Extended Repair Coverage                       | •                           | •                 | •                 | NI restores your device's functionality and includes firmware updates and factory calibration within < 10 working days [4] plus standard shipping time. |
| System Configuration, Assembly, and Test [1]   |                             | •                 | •                 | NI technicians assemble, install software in, and test your system per your custom configuration prior to shipment.                                     |
| Advanced Replacement [2]                       |                             |                   | •                 | NI stocks replacement hardware that can be shipped immediately if a repair is needed.   |
| System Return Material Authorization (RMA) [1] |                             |                   | •                 | NI accepts the delivery of fully assembled systems when performing repair services.   |
| Technical Support                              | •                           | •                 | •                 | NI provides access to support resources for your hardware.  |
| Calibration Plan (Optional)                    |                             | Standard          | Expedited [3]     | NI performs the requested level of calibration at the specified calibration interval for the duration of the service program.                           |

1 This option is only available for PXI, CompactRIO, and CompactDAQ systems.

2 This option is not available for all products in all countries. Contact your local NI sales engineer to confirm availability.

3 Expedited calibration is only available for the Traceable calibration level.

4 This applies to non-RF products only. Standard extended repair coverage for RF products is <15 working days plus standard shipping time.

## PremiumPlus Service Program

NI can customize the offerings listed above or offer additional entitlements such as on-site calibration, custom sparring, and life-cycle services through a [PremiumPlus Service Program](#). Contact your NI sales representative to learn more.

## Technical Support

NI hardware service programs and warranty include access to technical support provided by NI Support Agents during local business hours. Service requests can be managed online. Additionally, take advantage of NI's award winning [online resources](#) and [communities](#).

